

Liquid Chromatograph Mass Spectrometer

LCMS-8040

UFMS
ULTRA FAST MASS SPECTROMETRY



LCMS-8040

SHIMADZU

LIQUID CHROMATOGRAPH MASS SPECTROMETER

FW GAS HEATER STATUS POWER

LCMS-8040

— *Enhanced Sensitivity*



■ Ultra-High Sensitivity

By incorporating newly improved ion optics and collision cell technology, the LCMS-8040 provides higher multiple reaction monitoring (MRM) sensitivity. A five-fold increase in sensitivity (reserpine, S/N ratio), as compared with that of LCMS-8030 has been achieved by improving ion focusing and minimizing ion losses between multi-pole lenses. These improvements also yield higher sensitivity for scan mode measurements. This higher sensitivity expands the potential range of LC/MS/MS applications.

■ Ultra-High Speed

The LCMS-8040 was designed to provide significantly higher sensitivity while maintaining the high speed offered by the LCMS-8030. Ultrafast MRM transition speeds, up to 555 MRMs per second, are achieved by Shimadzu's UFsweeper collision cell technology, proprietary high-precision quadrupole machining capabilities, and unique high voltage power supply technology. In addition, the LCMS-8040 features the fast polarity switching at 15 msec. With this high-speed performance, the LCMS-8040 can dramatically improve analytical throughput.

■ Ultra-High Reliability

MRM optimization in Shimadzu's LCMS systems is based on a rapid series of automated flow injection analyses, requiring only minutes to perform. Multiple compounds can be optimized in an unattended sequence, freeing the analyst from tedious work. MRM parameters optimized for the LCMS-8030 can be transferred to the LCMS-8040, making it possible to transfer methods between systems. The LCMS-8040 offers the same ease of maintenance benefits as the LCMS-8030, and all consumables, such as desolvation lines (DL) and ESI capillaries, are interchangeable as well.

Speed Beyond Comparison

UFGMS

ULTRA FAST MASS SPECTROMETRY



GCMS-QP2010 Ultra
GCMS-QP2010 SE



GCMS-TQ8040



LCMS-8030



LCMS-8040



LCMS-8050



LCMS-8060



LCMS-2020



LCMS-IT-TOF

Ultra-High Sensitivity with UFMS Technology

Higher Sensitivity with Improved Ion Optics

UF-Lens™

The UF-Lens is a lens system that offers both higher sensitivity and easier maintenance. The optical system integrates two multi-pole RF ion guides for higher sensitivity. In addition, the lens system can be removed without tools for easy cleaning.

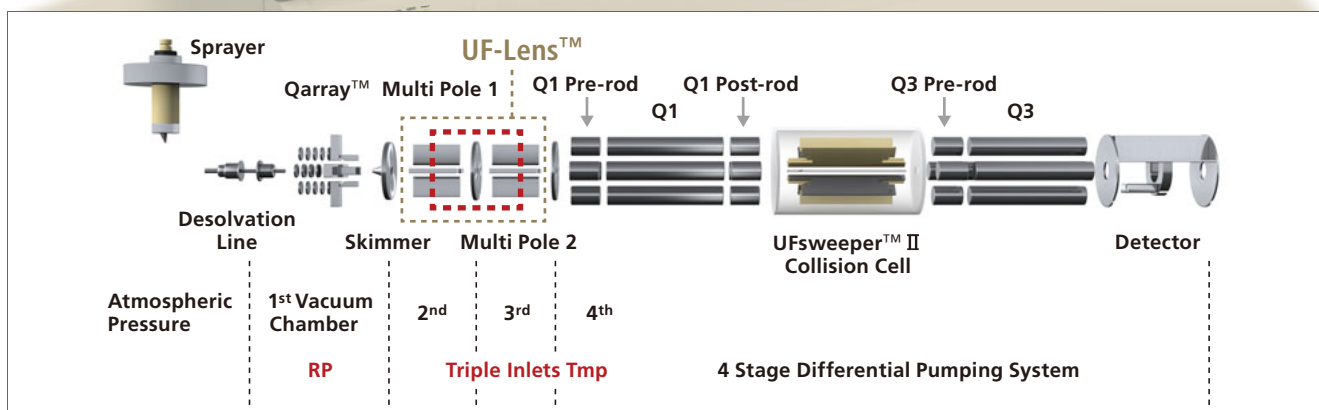

Ion losses between segments are minimized by utilizing quadrupole ion guides.

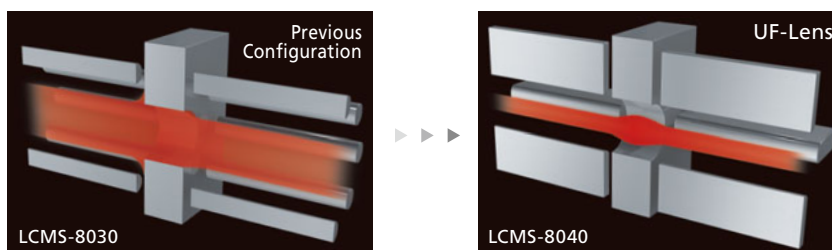

A comparison of auto-tune Q1 scan results for a standard sample (a mixture of PEG, PPG, and raffinose) obtained from the LCMS-8030 and LCMS-8040 is shown to the right. Target ions used for ESI+ auto-tuning are plotted (m/z 65.05, 168.10, 256.15, 344.20, 652.40, 1004.60, and 1224.75). A significant sensitivity increase across a broad molecular weight range for precursor ion transmission is demonstrated.

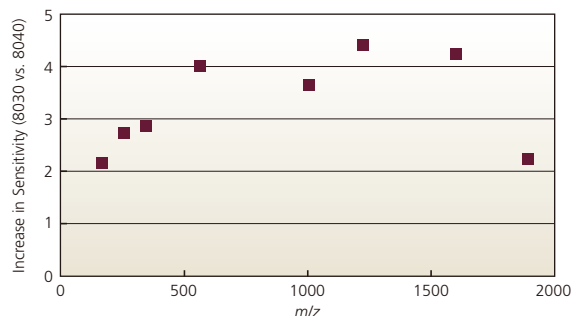

Higher CID Efficiency with Improved Collision Cell

UFsweeper™ II

The UFsweeper II is a high-sensitivity, high-speed collision cell that features improved ion focusing by using high-speed ion transport technology. This yields better product ion transmission in the collision cell, maintaining signal intensity and suppressing crosstalk, even for high-speed or simultaneous multi-component analysis. The capability for high-throughput analysis is thus maintained at lower levels of detection.

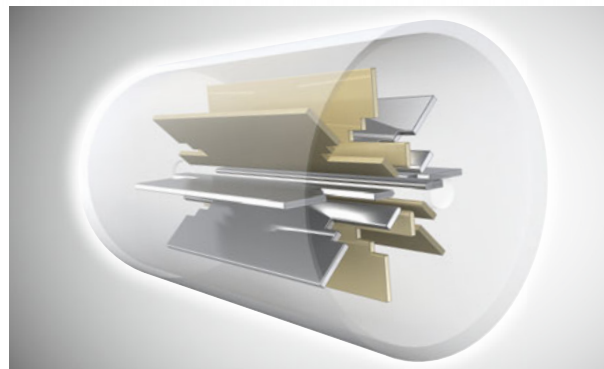

Sample Name	Precursor <i>m/z</i>	Product <i>m/z</i>	LCMS-8030 CID efficiency	LCMS-8040 CID efficiency	Proportional Increase
Lidocaine	235.4	86.1	20.0	29.0	1.4
Atropine	290.1	124.1	7.2	11.0	1.5
Yohimbine	355.1	144.0	9.5	15.6	1.6
Tetracaine	265.1	176.1	15.7	32.0	2.0
Doxepin	280.1	107.1	4.4	7.2	1.6
Imipramine	281.1	86.1	16.2	22.1	1.3
Nortriptyline	264.1	233.1	3.8	7.4	1.9
Isopropylantipyrine	231.1	188.9	1.5	2.9	1.9
Diazepam	285.0	154.0	2.4	3.9	1.6
Reserpine	609.3	195.1	3.9	6.6	1.7

The LCMS-8040 offers higher sensitivity while maintaining the ultrafast performance of the LCMS-8030. The figures below show simultaneous analysis of 167 pesticides in MRM positive/negative ion analysis mode. Even though positive and negative ions were

measured simultaneously, both the LCMS-8030 and LCMS-8040 accurately identified all 167 components. In addition, the LCMS-8040 showed improved sensitivity – an average of three times higher for all components.

■ LCMS-8030

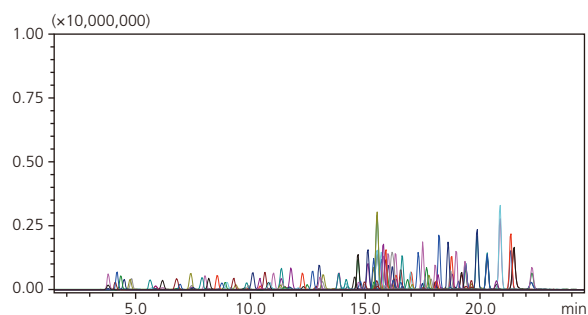

■ LCMS-8040

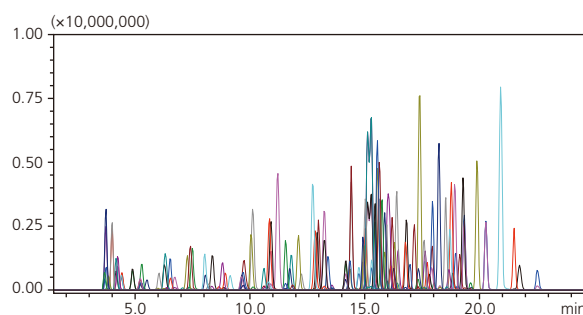

HPLC

Analysis Column	Shim-pack FC-ODS (2.0 mm I.D. x 150 mm L., 3 μm)
Mobile Phase A	5 mmol/L ammonium acetate - Water
Mobile Phase B	5 mmol/L ammonium acetate - Methanol
Gradient Program	15 %B (0 min) – 40 %B (1–3.5 min) – 50 %B (6 min) – 55 %B (8 min) – 95 %B (17.5–30 min) – 15 %B (30.01–40 min)
Flow Rate	0.2 mL/min
Column Temperature	40 °C

MS

Probe Voltage	+4.5 kV (ESI-Positive mode) / -3.5 kV (ESI-Negative mode)
Nebulizing Gas Flow	1.5 L/min
Drying Gas Flow	10 L/min
DL Temperature	250 °C
Heat Block Temperature	400 °C

Proven Ultra-High Performance now with Enhanced Sensitivity

Higher Sensitivity for Q1 Full Scan Spectra

The LCMS-8040 maintains the same high-speed scanning (UFscanning) and polarity switching technology (UFswitching) utilized in the LCMS-8030.

The LCMS-8040 not only maintains Shimadzu's proprietary high-speed technologies (UF Technologies, USP7855355, USP8188426), which minimize sensitivity losses even at faster scan speeds, it also features improved ion optics, which provide higher sensitivity for MRMs and full scans. A comparison of Q1 full scan spectra for

pesticide samples (Methomyl, Carbaryl(NAC), Phoxim, Benfuracarb, and Abamectin B1a) is shown below. The upper spectra were acquired using the LCMS-8040 and the lower spectra were acquired using the LCMS-8030. As shown, the LCMS-8040 offers significant sensitivity improvements for precursor ions or full scan data.

LCMS-8040

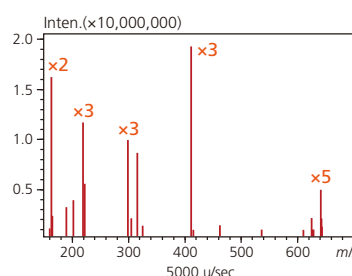
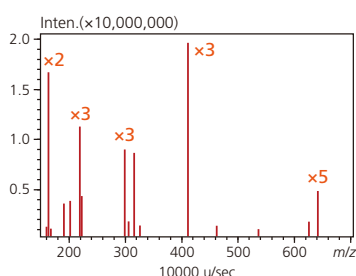
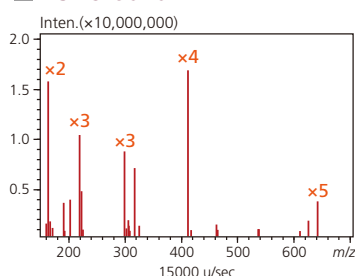

LCMS-8030

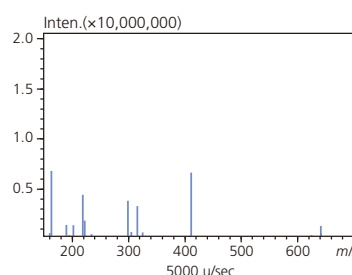
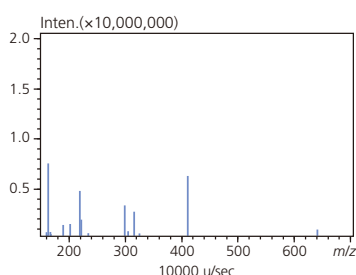
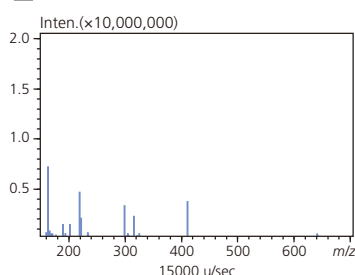

Proven Interface for Robust Performance

Robust, User-Friendly Interface

The LCMS-8030 and LCMS-8040 use the same interface. In LCMS analysis, it is necessary to adjust interface conditions such as temperatures and gas flow rates for optimal desolvation. Spray needle adjustment and probe position are also factors to be evaluated. In both the LCMS-8030 and LCMS-8040, temperatures and flows are easily controlled through the software. ESI probe position is set by a single easily accessible knob, and spray needle protrusion is adjusted without the need for any special tools or disassembly of the probe. In addition, this capillary incorporates a tapered design, which reduces sample clogging.

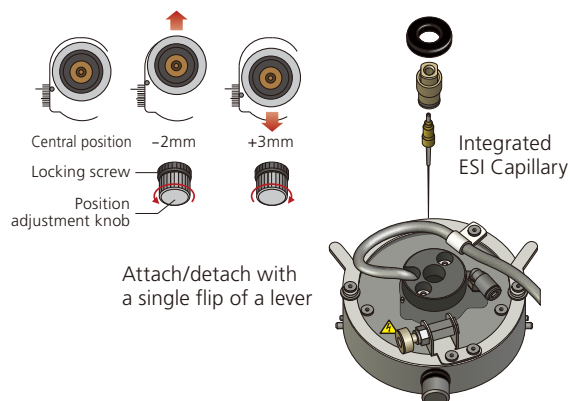

Higher Sensitivity for MS/MS Acquisition Modes

The increased scan sensitivity of the LCMS-8040 also applies to scan modes specific to triple quadrupole mass spectrometers, such as product ion scanning, precursor ion scanning, and neutral loss scanning. Historically, mass spectrometers have introduced mass deviation in linked scans, such as precursor ion scans or neutral loss scans, when measured at maximum scan speeds.

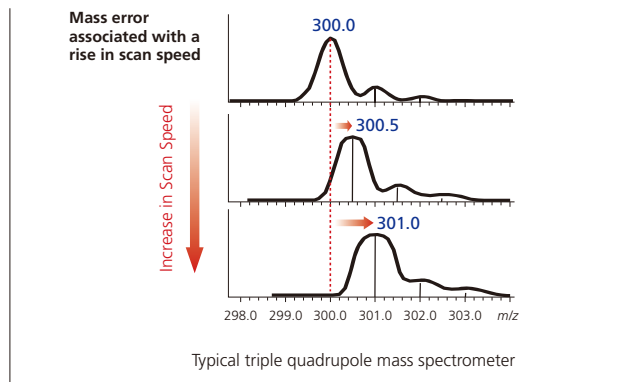
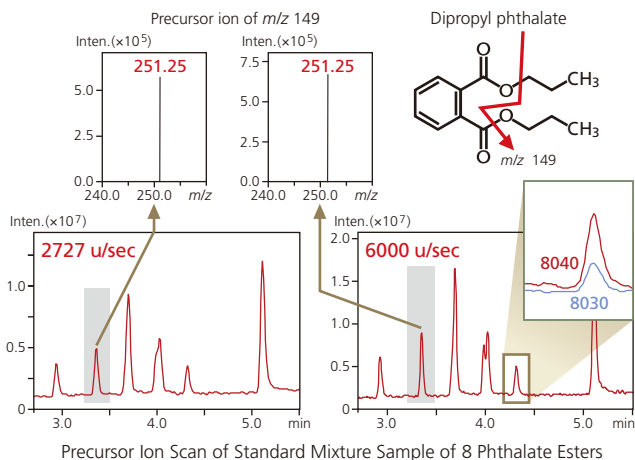

However, Shimadzu's proprietary UFscanning technology allows performing precursor ion scans or neutral loss scans at high speeds without loss of mass accuracy. In addition, the LCMS-8040 offers higher sensitivity levels. Precursor scan results for eight kinds of phthalate esters are shown to the left. Scans were performed at two speeds, 2727 u/sec and 6000 u/sec. No mass shift is observed at either scan speed, and a significant sensitivity improvement is observed for the LCMS-8040.

Easy Method Transfer

MRM parameters for the LCMS-8030 can be used in LCMS-8040 systems.

Optimization of MRM parameters is an early step in LCMS method development. Shimadzu has streamlined the MRM optimization process with a rapid and simplified approach based on automated flow injection analysis. Several method packages, which contain chromatographic and optimized MRM conditions for a variety of analytes, including residual pesticides, veterinary drugs, and forensic drugs of abuse, have also been released. Laboratories

employing LCMS-8030 MRM conditions will be able to transfer these MRMs directly to the LCMS-8040. To demonstrate this, a method for the simultaneous analysis of 167 pesticides was transferred without modification from the LCMS-8030 to the LCMS-8040. Increased sensitivity was obtained for all compounds; three example chromatograms are shown below.

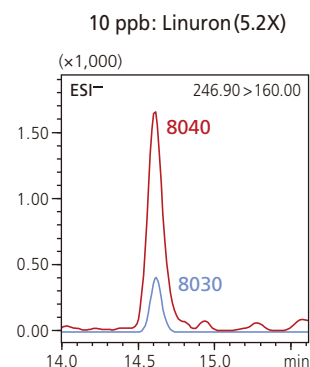
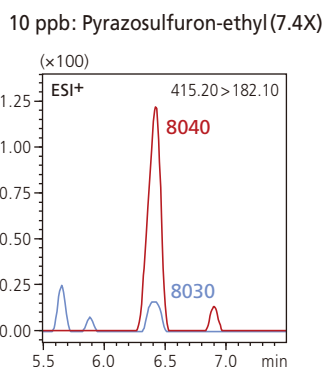
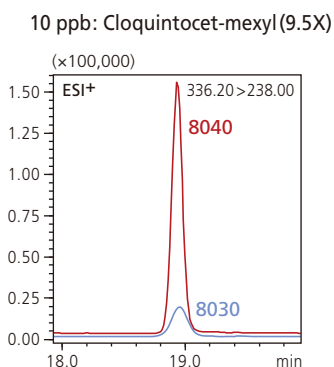

Ultra-High Reliability to Withstand Wide Range of Complex Matrices

Exceptional Durability

Blood plasma samples were spiked with verapamil and warfarin, and then deproteinized according to the pretreatment process indicated below. The area values from 450 consecutive LCMS-8040 analyses were then plotted. Simultaneous analysis of verapamil by ESI⁺ and

warfarin by ESI⁻ was performed. Chromatograms for the 1st, 250th, and 450th measurements are shown below. This resulted in 1 pg on-column area repeatability of 4.18 % for verapamil and 6.61 % for warfarin.

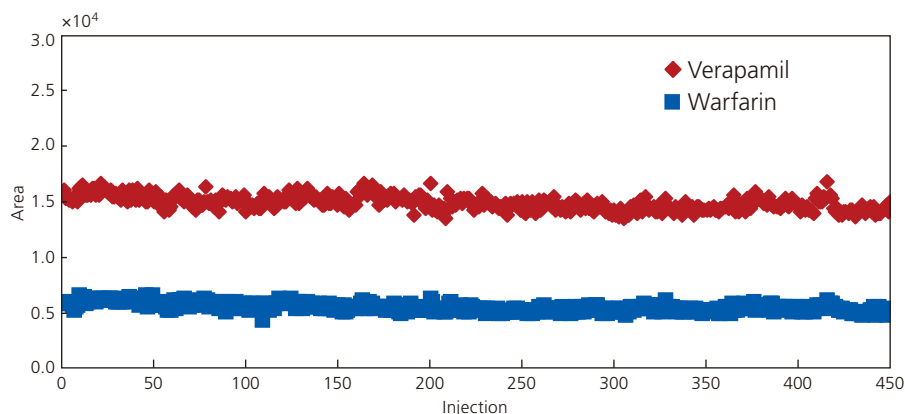

Column: Shim-pack XR-ODS II (2.0 mm I.D. x 50 mm L, 2.2 μm)
 Mobile Phase A: 5 mmol/L ammonium acetate–water
 Mobile Phase B: Acetonitrile
 Gradient Program:
 60 % B (0–1.50 min) –
 90 % B (1.51–3.00 min) –
 60 % B (3.01–4.50 min)
 Flow Rate: 0.4 mL/min.

200 μL plasma sample
 Add 200 μL Acetonitrile, 50 μL 50 % methanol aqueous solution and 50 μL verapamil and warfarin standard solutions.
 Vortex and centrifuge (10000 rpm, 3 min.) followed by freeze drying.
 Add 500 μL dilution solution.
 Vortex and centrifuge (12000 rpm, 5 min.).

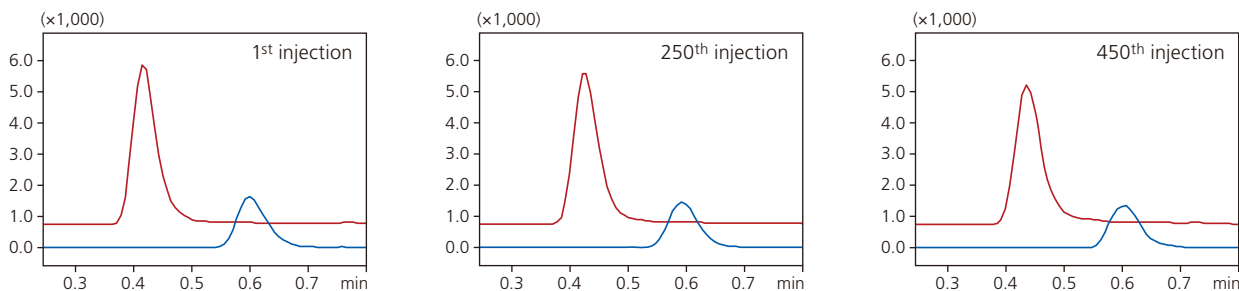

Ultra Fast Speed Combined with Lower Femtogram Detection

Using the same chromatography parameters as described above, analysis of plasma samples spiked with 40 fg/μL verapamil and warfarin were injected into the LCMS-8040 for signal to noise determination. For 100 fg on-column, a S/N ratio of 146 (rms) was obtained for verapamil and 30 (rms) for warfarin.

The resulting lower limits of detection for S/N = 3 (rms) were 2.05 fg for verapamil and 9.88 fg for warfarin.

Compounds	Verapamil	Warfarin
S/N: 100 fg on column (rms)	146	30
LOD (fg) Calculated at S/N = 3	2.05	9.88

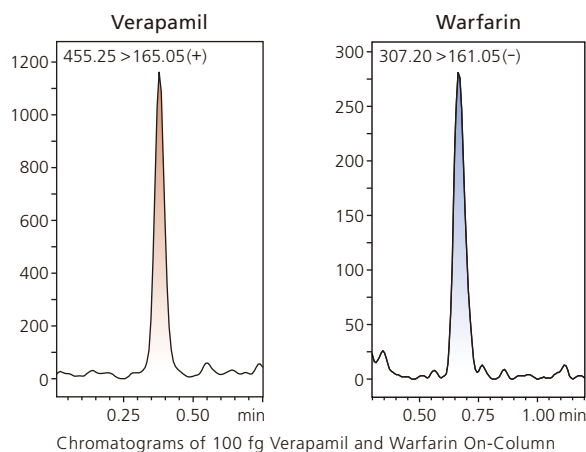

Chromatograms of 100 fg Verapamil and Warfarin On-Column

Single Vendor Solution Provides Seamless Operation LabSolutions LCMS Version 5

LabSolutions LCMS Version 5 is integrated workstation software used to control LCMS-8030/8040/8050/8060 systems. Full HPLC control is included for LC-VP and Prominence modules, and for the Nexera UHPLC series. Standard data processing features include a Quantitation Browser, which is useful for quantitative processing of multiple analytes, and a Data Browser for overlaying chromatograms.

The Data Browser allows the user to analyze and compare multiple sets of data, such as peak detection data or LCMS spectra in the same window. It also allows LC and MS data to be linked, which is especially useful when searching for or identifying compounds. In addition, the popular report function was expanded to enable printing results in a wider variety of formats.

Automatic MRM Optimization

Optimizing MRM parameters is an important step when creating quantitative methods for triple quadrupole mass spectrometers. LCMS-8030/8040/8050/8060 systems optimize MRM parameters using automated flow injection analysis, an optimization function included LabSolutions that allows anyone to optimize parameters easily.

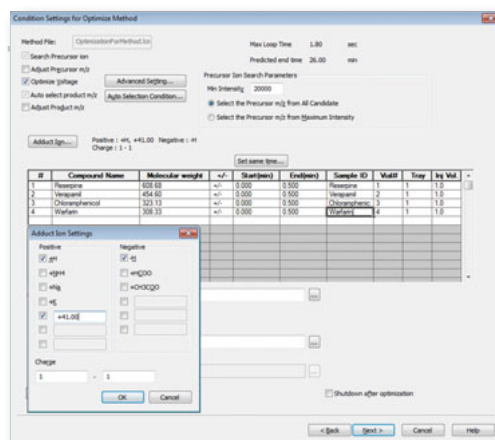
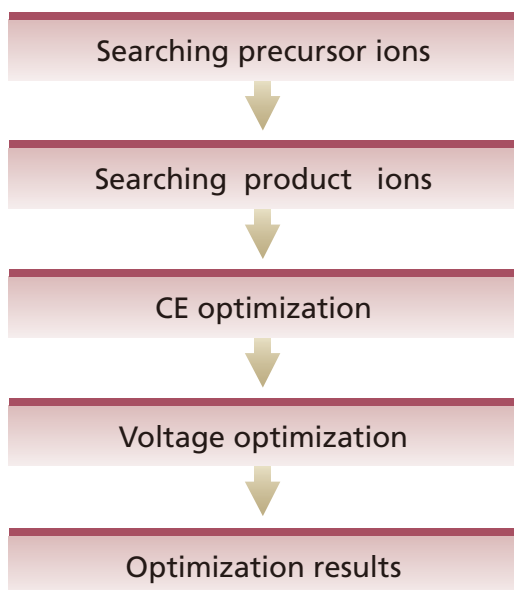

If a precursor ion is unknown, the software automatically searches for the ion.

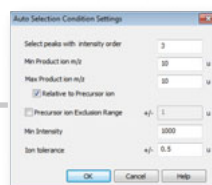

If a product ion is unknown, the software automatically searches for the ion.

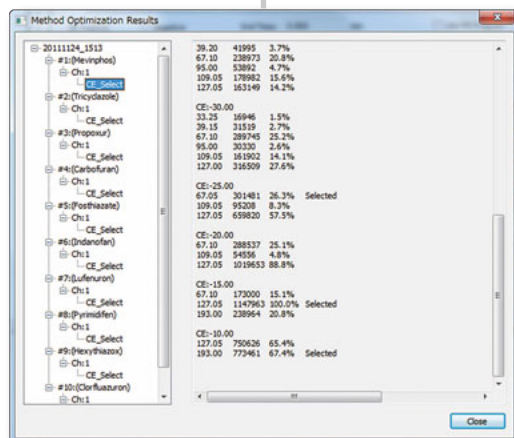

Optimization results are automatically reflected in method files, and shown in the window above. The user can easily make edits to the final method.

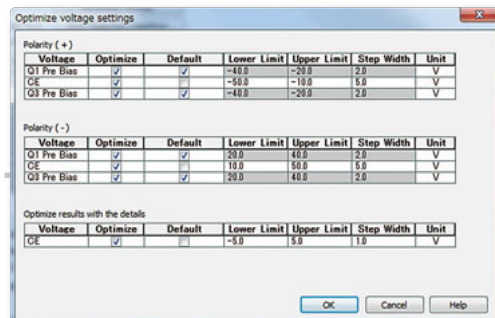

Optimization choices include voltages for Q1 pre-rod, Q3 pre-rod, and Collision Energy.

Powerful Workflow Solutions

When performing quantitation, system parameters must first be optimized. Shimadzu offers various method packages and MRM library to eliminate the need for MRM determination and chromatographic method development.



	Description	Flyer code
Method packages	Residual Pesticides	C146-E160
	Veterinary Drugs	C146-E161
	Water Quality Analysis	C146-E180
	Drugs of Abuse	C146-E181
	Rapid Toxicology Screening	C146-E224
	Primary Metabolites	C146-E227
	Lipid Mediators	C146-E225
	Cell Culture Profiling	C146-E279
MRM Library	Metabolic Enzymes in Yeast	C146-E275

Quan Solution

Open Access Software for Triple Quadrupole LC/MS/MS Quantitative Analysis

With sample logging now made easy, Quan Solution allows users unfamiliar with LCMS software the capability to perform LC/MS/MS analysis using pre-set methods. Simple screens allow users to access the power of a triple quadrupole LCMS without extensive training.

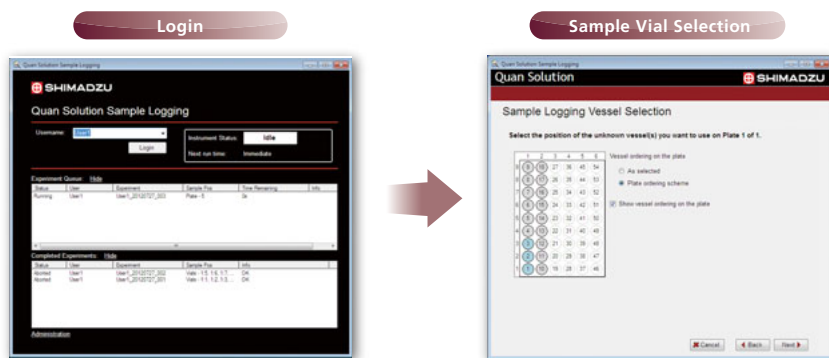

Sample registration by selecting the standard samples, unknown samples, and QC samples at the specified positions

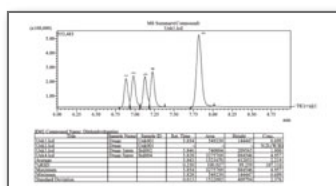

Quantitative Reports Received Via E-mail



Analysis

Profiling Solution

Software for Profiling Analysis

Profiling Solution software analyzes a huge amount of data from chromatograms, extracting every peak from multiple data files and creating a data table, which is required for multivariate analysis. Profiling Solution supports both LC/MS and GC/MS instruments and allows multivariate analysis with various analytical methods.

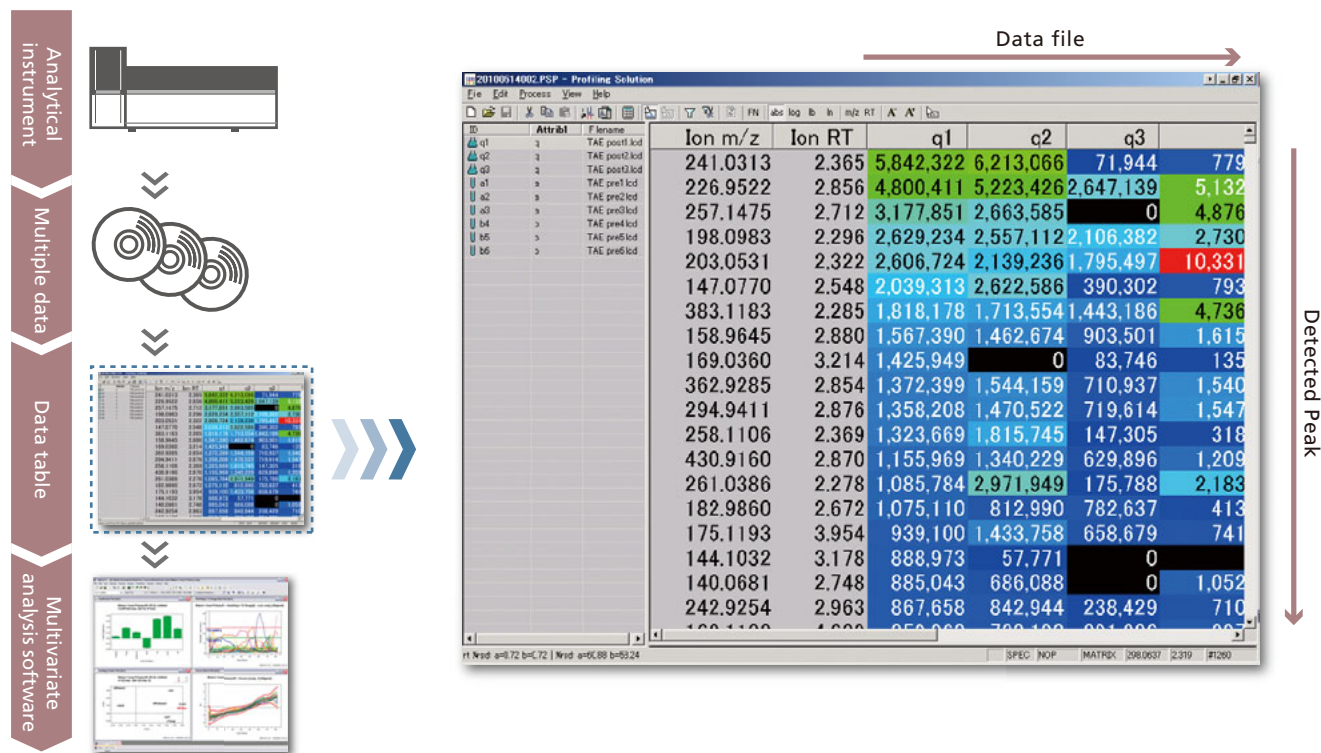

Optional Ion Source

Changing between ESI, APCI and DUIS interface is a completely tool-free operation.

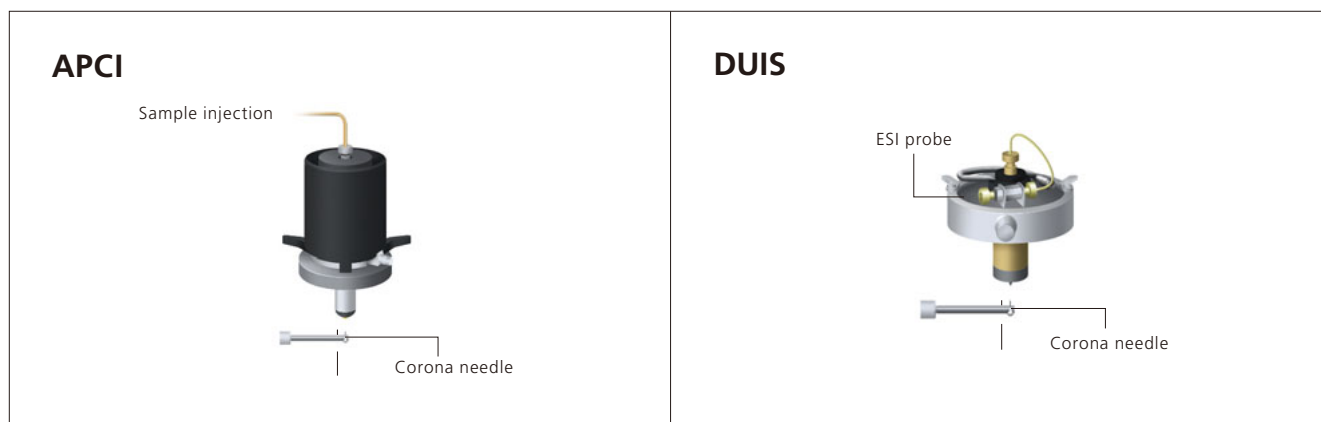



Shimadzu Corporation
www.shimadzu.com/an/

Company names, product/service names and logos used in this publication are trademarks and trade names of Shimadzu Corporation or its affiliates, whether or not they are used with trademark symbol "TM" or "®".
Third-party trademarks and trade names may be used in this publication to refer to either the entities or their products/services. Shimadzu disclaims any proprietary interest in trademarks and trade names other than its own.

For Research Use Only. Not for use in diagnostic procedures.
The contents of this publication are provided to you "as is" without warranty of any kind, and are subject to change without notice. Shimadzu does not assume any responsibility or liability for any damage, whether direct or indirect, relating to the use of this publication.